

# OPERATOR'S MANUAL

# 65179X-XXX-B

INCLUDING: SERVICE KITS, TROUBLESHOOTING, PARTS LIST,  
DISASSEMBLY & REASSEMBLY.

RELEASED: 6-18-92  
REVISED: 2-23-09  
(REV. K)

## LOW PRESSURE MATERIAL REGULATOR



**READ THIS MANUAL CAREFULLY BEFORE INSTALLING,  
OPERATING OR SERVICING THIS EQUIPMENT.**

It is the responsibility of the employer to place this information in the hands of the operator. Keep for future reference.  
The original language of this manual is English.

### SERVICE KITS

- Use only genuine ARO® replacement parts to assure compatible pressure rating and longest service life.
- Order 637219-XXX-B rebuild kit (see chart below) for general repair of the regulator. This includes a diaphragm kit and a valve kit.
- Fluid diaphragm kit 62173 can be ordered separately (see page 4).
- Valve kit can be ordered separately (see page 4).

### REBUILD KIT DESCRIPTION CHART

637219 - XXX - B	
<b>Type</b> 2 - Downstream 3 - Back Pressure	
<b>Ball Size</b> A - 0.1875" B - 0.250" C - 0.500"	
<b>Ball &amp; Seat Material</b> 1 - Tungsten Carbide 2 - 400 Series Stainless Steel 4 - 300 Series Stainless Steel	
<b>Rebuild Kit Selection</b> Example: Model # 651790-A1D-B Rebuild Kit # 637219-2A1-B	

### SPECIFICATIONS

<b>Model Series</b> .....	65179X-XXX-B
<b>Type</b> .....	651790-XXX-B Downstream 651791-XXX-B Back Pressure
<b>Material Inlet</b> .....	see model chart
<b>Material Outlet</b> .....	see model chart
<b>Dimensional Data</b> .....	see figure 10

### PERFORMANCE DATA

<b>Regulated Pressure Range</b> .....	see model chart
<b>Maximum Regulated Pressure</b> .....	see model chart
<b>Maximum Inlet Pressure</b>	
651790-A4X-B, -B4D-B, -BXR-B .....	500 p.s.i. (34.5 bar)
651790-A1X-B, -A3X-B, -B1C-B .....	750 p.s.i. (51.7 bar)
651790-B1D-B, -B3D-B, -BXE-B .....	1250 p.s.i. (86.2 bar)
651791-BXD-B, -B3C-B, -CXD-B .....	200 p.s.i. (13.8 bar)
651791-BXE-B .....	800 p.s.i. (55.2 bar)
<b>Maximum Temperature Limits</b> .....	0° to 200° F (-18° to 93° C)

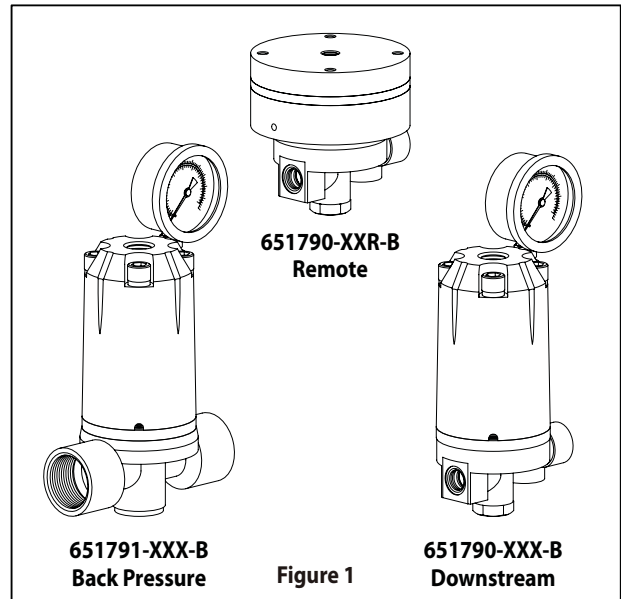

### MODEL DESCRIPTION CHART

65179 X - XXX - B	
<b>Type</b> 0 - Downstream 1 - Back Pressure	
<b>Port Size, (Ball Size)</b> A - 3/8 - 18 NPTF (0.1875") B - 3/8 - 18 NPTF (0.250") C - 1-1/4 - 11-1/2 NPTF (0.500")	
<b>Body Material, (Seat, Stem Material)</b> 1 - Zinc (Tungsten Carbide, Tungsten Carbide) 2 - Stainless Steelⓐ (Stainless Steelⓐ, Stainless Steelⓐ) 3 - Stainless Steelⓐ (Tungsten Carbide, Tungsten Carbide) 4 - Stainless Steelⓐ (Stainless Steelⓐ, Stainless Steelⓐ) 5 - Stainless Steelⓐ (Stainless Steelⓐ, Tungsten Carbide)	
<b>Regulated / Maximum Pressure Range</b> B - 5 - 30 p.s.i. (0.3 - 2.1 bar) Downstream models C - 20 - 60 p.s.i. (1.4 - 4.1 bar) Downstream models 20 - 60 p.s.i. (1.4 - 4.1 bar) Back Pressure models D - 50 - 200 p.s.i. (3.4 - 13.8 bar) -AXD Downstream models - 30 - 200 p.s.i. (2.1 - 13.8 bar) -BXD Downstream models - 0 - 200 p.s.i. (0 - 13.8 bar) Back Pressure models E - 100 - 800 p.s.i. (6.9 - 55.2 bar) Downstream models - 0 - 800 p.s.i. (0 - 55.2 bar) Back Pressure models R - 30 - 200 p.s.i. (2.1 - 13.8 bar) Remote models	
ⓐ 300 series stainless steel ⓑ 400 series stainless steel	

## OPERATING AND SAFETY PRECAUTIONS



EXCESSIVE AIR PRESSURE  
STATIC SPARK



HAZARDOUS MATERIALS  
HAZARDOUS PRESSURE

- Read and heed all warnings, cautions and safety precautions before operation of this unit.
- Be certain anyone operating this equipment or fluid system has been trained to use it safely.

**⚠️ WARNING HIGH PRESSURE DEVICE.** Improper usage of this equipment could result in serious injury. The possibility of injection into the flesh is a potential hazard. Wear approved safety glasses or face shield and other equipment as needed to prevent injury. Never allow any part of the human body to come in front of, or in contact with, the material outlet, the tip, or the material outlet of the dispensing device. An injection injury can be serious. If an injection accident should occur, it is very important that you contact a qualified physician for immediate treatment.

**⚠️ WARNING MISAPPLICATION HAZARD.** Do not use the regulator when the fluid inlet pressure is too high for the designed operating range. Excessive inlet pressure can cause a lock-out situation. Lock-out occurs when the inlet pressure is beyond the regulator's spring capacity. The valve will not open. Attempts to disassemble components while in a lock-out condition may result in injury.

**⚠️ WARNING COMPONENT RUPTURE.** Do not operate regulator at an inlet pressure greater than specified. To avoid possible damage or personal injury, do not operate this unit at pressure higher than the stated operating range as it appears on the model plate.

**⚠️ WARNING DISASSEMBLY HAZARD.** Do not disassemble this regulator when it is under pressure. Relieve pressure in the pumping system before attempting service or disassembly procedures. Disconnect air lines and carefully bleed pressure off the system. Be certain the system is not maintaining pressure due to a material restriction in the hose, line, dispensing device, or the spray or extrusion tip. Failure to relieve pressure, both up stream and downstream, may result in an injury upon disassembly.

**⚠️ WARNING BONNET REMOVAL HAZARD.** Do not attempt to remove the four bonnet retaining bolts without first relieving the tension on the main spring. Failure to relieve tension could result in an accident upon disassembly.

**⚠️ WARNING PREVENT FIRES.** Keep solvents away from heat, sparks or open flame. Keep containers closed when not in use. When pumping, flushing or recirculating volatile solvents, be certain the area is adequately ventilated.

**⚠️ CAUTION FLUSH SUPPLY LINE.** Before installing fluid regulator, blow the supply lines clear and flush to remove contaminates.

<b>⚠️ WARNING</b>	= Hazards or unsafe practices which could result in severe personal injury, death or substantial property damage.
<b>⚠️ CAUTION</b>	= Hazards or unsafe practices which could result in minor personal injury, product or property damage.
<b>NOTICE</b>	= Important installation, operation or maintenance information.

## INSTALLATION

- Refer to the typical installation view which best applies.
- Locate the regulator as close as possible to the spray gun or dispensing device for best pressure control.
- Identify the regulator INLET / OUTLET (flow direction). The regulator is marked with an arrow on the body base.
- Flush supply line before installing regulator.
- Remote models require maximum 100 p.s.i. (6.9 bar) signal pressure. Start with a signal pressure as low as possible and adjust upward until proper flow is reached.

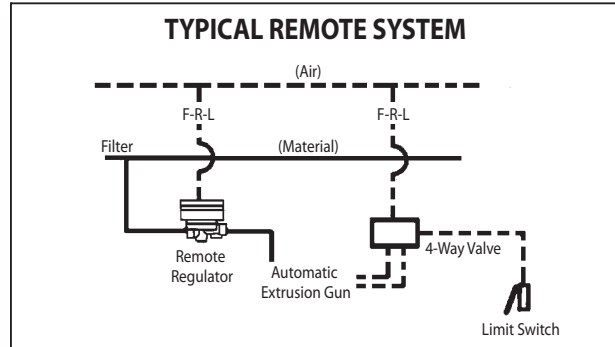
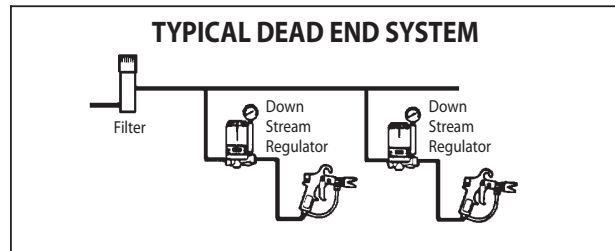
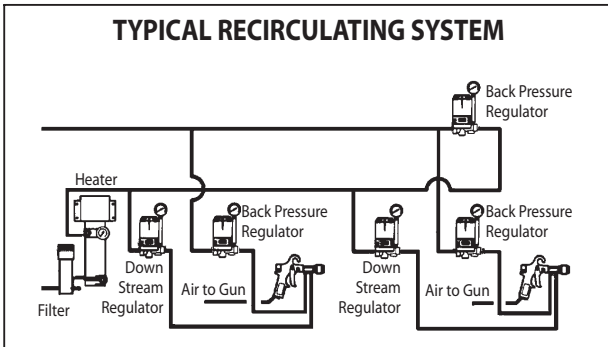

Figure 2

• ARO® is a registered trademark of Ingersoll Rand Company • Loctite® and 242® are registered trademarks of Henkel Loctite Corporation •  
• Perma-Lok® is a registered trademark of National Starch and Chemical Corporation •

## OPERATING INSTRUCTIONS

Refer to pages 4 and 5 for parts reference.

- To **INCREASE** outlet pressure, turn the (6) adjusting screw **CLOCKWISE** (see figure 3).
- To **DECREASE** outlet pressure, turn the (6) adjusting screw **COUNTERCLOCKWISE** (see figure 3).

NOTE: Part Y106-109 Allen wrench is included to make necessary pressure adjustments.

### FLUSH-OUT FEATURE FOR DOWNSTREAM MODELS ONLY.

See figure 4.

- Flush the regulator periodically. The interval may vary depending on the amount and type of material used.
- By using a wrench and “flush-out” plug (provided), the operator is able to move the entire spindle downward and force the ball off the seat which should purge the regulator of particle build-up.

NOTE: The flush-out procedure temporarily overrides the adjusted pressure. It will not, however, affect the regulator setting when flushing operation is completed.

### FLUSH-OUT PROCEDURE

1. Remove spray gun or dispensing device, this will allow any particles to clear from the system.
2. Insert (21) flush-out plug and turn clockwise until it touches the (4) washer (see view on page 5).
3. Turn up to two turns maximum. This will allow the ball to unseat and pass material at free flow (unregulated). **DO NOT** attempt to turn further to avoid damage.
4. Turn the plug back to its original position.

### SEAT PLUG FEATURE

The (47) plug, located at the base of the regulator, can be removed for access to the ball and seat assembly for cleaning and inspection for wear. With this feature, the regulator does not have to be unthreaded from the pumping system. Be certain to relieve system pressure (See “WARNING: DISASSEMBLY HAZARD”).

## MAINTENANCE

- Disassembly should be done on a clean work bench and use clean cloths.
- If replacement parts are necessary, refer to the parts list and drawings on pages 4 and 5.
- Upon reassembly, lubricate parts and use Loctite where indicated. Follow the torque specifications as shown.
- Service kits are available, which include parts typically needed for an overhaul.
- Keep good records of service activity and include the regulator in a preventive maintenance program.
- Certain “Smart Parts” are indicated with a “1” in the parts list, these parts should be available for fast repair and reduction of down time.

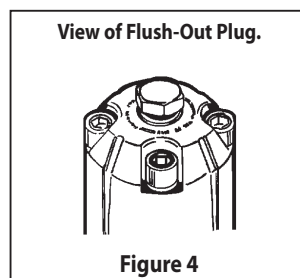
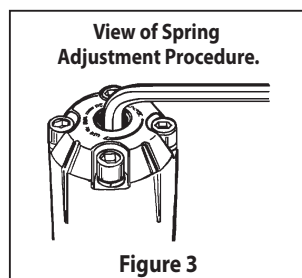

## TROUBLE SHOOTING

### No fluid pressure.

- Check for damaged or worn diaphragms.
- Look for possible obstruction by hardened material or foreign matter, periodically use the regulator “flush-out” feature (downstream models only). Use a fluid filter upstream from the regulator.

### Pressure creeps above the setting when system is dead ended and in a static (no flow) mode.

- Check for dirty seat and clean as appropriate.
- Check for worn or damaged seat and replace if necessary.

### Outlet pressure drops below setting.

- Check pump for proper operation and check for possible leakage problems.
- Look for a clogged supply line problem, flush the supply line.

### Fluid leakage from spring housing.

- Check the bonnet hold-down screws and the plate hold down screws and re-torque as needed.
- Check for damaged diaphragm, replace as needed.

### Regulator will not function, even when dispensing device is opened.

- Check for possible obstruction in the fluid line.
- Inlet pressure is too high, causing a “lock-out” situation. Read “WARNING: MISAPPLICATION HAZARD” found on page 2.

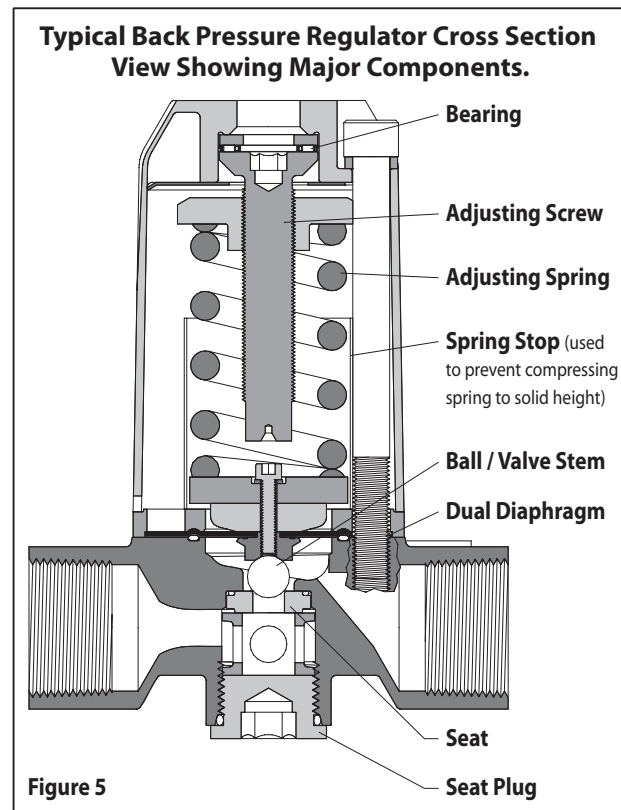

## PARTS LIST / 65179X-XXX-B

### 65179X-XXX-B COMMON PARTS

Item	Description (size)	Qty	Part No.	[Mtl]	Item	Description (size)	Qty	Part No.	[Mtl]
1	Housing - 651790-XXX-B (downstream)	(1)	93534-1	[A]	22	Spring Stop - 651790-XXB-B (1.597" long)	(1)	96348-1	[SS]
	651791-XXX-B (back pressure)	(1)	93534-2	[A]		651790-XXC-B (2.265" long)	(1)	96348-2	[SS]
2	Bolt (7/16" - 20 x 5")	(4)	93487-2	[C]		651790-XXD-B (2.125" long)	(1)	96348-3	[SS]
3	Washer (7/16" i.d.)	(4)	Y79-716	[C]		651790-XXE-B (2.359" long)	(1)	96348-4	[SS]
4	Washer (1.162" o.d. x 0.125" thick)	(1)	93485-1	[C]	23	Long Nipple (1/4 - 18 NPT x 4")	(1)	Y44-15-S	[SS]
5	Thrust Bearing (1.173" o.d.)	(1)	93484-1	[C]	24	Coupling (1/4 - 18 NPT x 1-3/8")	(1)	Y43-242-S	[SS]
6	Adjusting Screw (5/8" - 24, left hand)	(1)	93486-1	[C]	25	Gauge - models 65179X-X1B-B and -X1C-B (0 - 60 p.s.i. / 0 - 4 bar)	(1)	93656-1	[Br/Bz]
7	Plate	(1)	93818	[SS]		models 65179X-X1D-B (0 - 300 p.s.i. / 0 - 20 bar)	(1)	93887	[Br/Bz]
8	Adjusting Nut	(1)	93481-1	[C]		models 65179X-X1E-B (0 - 1000 p.s.i. / 0 - 70 bar)	(1)	93503-1	[Br/Bz]
9	Spring - 65179X-XXB-B (green, 10 - 30 in. lbs)	(1)	93636-1	[C]		models 65179X-X3B-B, -X3C-B, -X4B-B and -X4C-B (0 - 60 p.s.i. / 0 - 4 bar)	(1)	93657-1	[SS]
	65179X-XXC-B (orange, 20 - 60 in. lbs)	(1)	93637-1	[C]		models 65179X-X3D-B and -X4D-B (0 - 300 p.s.i. / 0 - 20 bar)	(1)	93888	[SS]
	65179X-XXD-B (gray, 50 - 200 in. lbs)	(1)	93638-1	[C]		models 65179X-X2E-B, -X3E-B and -X4E-B (0 - 1000 p.s.i. / 0 - 70 bar)	(1)	93504-1	[SS]
65179X-XXE-B (red, 100 - 800 in. lbs)	(1)	93639-1	[C]	26	Stud (7/16" - 20 x 4") models 651790-B5R-B	(2)	92987	[C]	
10	Screw (#10 - 32 x 7/8")	(1)	Y191-107	[C]	all models except 651790-B5R-B	(1)	92987	[C]	
11	Lockwasher (0.196" i.d.)	(1)	Y14-10	[C]	27	Nut (7/16" - 20) models 651790-B5R-B	(4)	Y11-7-C	[C]
13	Small Plate	(1)	93893	[C]	all models except 651790-B5R-B	(2)	Y11-7-C	[C]	
14	Button	(1)	93889	[A]	28	Lock Washer (7/16") models 651790-B5R-B	(2)	Y14-716	[C]
15	Plate	(1)	93633-2	[C]	all models except 651790-B5R-B	(1)	Y14-716	[C]	
16	Diaphragm (0.062" thick, black)	(1)	93883	[N]	⊕	Indicates parts included in the diaphragm service kit		62173	
17	Diaphragm (0.020" thick, white)	(1)	93630-1	[T]					
18	"O" Ring (3/32" x 1-7/8" o.d.)	(1)	Y328-131	[T]					
20	3/8" Allen Wrench	(1)	Y106-109	[C]					
21	Flush-Out Plug (used on models 651790-XXX-B only)	(1)	93819	[C]					

### 651790-XXX-B DOWNSTREAM REGULATORS

Flow / Size	-XXX	Port Size NPTF	Ball Size	⊕ Rebuild Kit	⊕ Valve Stem (40)	⊕ Valve Kit (41, 42, 43, 44) (see below)	⊕ Flow Tube (45)	"O" Ring (46)	⊕ Base Plug Ass'y (47) ⊕	Base (48)	Pipe Plug (52)
Standard	-A1X	3/8	0.1875"	637219-2A1-B	92989	62169	93489-1	93492-1	62168	93650-1	Y17-52-N
	-A3X	3/8	0.1875"	637219-2A1-B	92989	62169	93489-1	93492-1	62168	93651-1	Y17-52-S
	-A4X	3/8	0.1875"	637219-2A4-B	93640-1	62171	93489-1	93492-1	62168	93651-1	Y17-52-S
Hi-Flow	-B1X	3/8	0.250"	637219-2B1-B	92989	62237	93489-1	93492-1	62168	93650-1	Y17-52-N
	-B2X	3/8	0.250"	637219-2B2-B	93640-1	62238	93489-1	93492-1	62168	93651-1	Y17-52-S
	-B3X	3/8	0.250"	637219-2B1-B	92989	62237	93489-1	93492-1	62168	93651-1	Y17-52-S
	-B4X	3/8	0.250"	637219-2B4-B	93640-1	62239	93489-1	93492-1	62168	93651-1	Y17-51-S
	-B5X	3/8	0.250"	637219-2B4-B	92989	62239	93489-1	93492-1	62168	93651-1	Y17-51-S

### 651791-XXX-B BACK PRESSURE REGULATORS

Flow / Size	-XXX	Port Size NPTF	Ball Size	⊕ Rebuild Kit	⊕ Valve Stem (40)	⊕ Valve Kit (41, 42) (see below)	⊕ Flow Tube (45)	"O" Ring (46)	⊕ Base Plug Ass'y (47) ⊕	Base (48)	Pipe Plug (52)
Hi-Flow	-B1X	3/8	0.250"	637219-3B1-B	93641-1	61985-1	93489-1	93492-1	62168	93650-1	Y17-51-N
	-B3X	3/8	0.250"	637219-3B1-B	93641-1	61985-1	93489-1	93492-1	62168	93651-1	Y17-51-S
	-B4X	3/8	0.250"	637219-3B4-B	98576-1	66881-1	93489-1	93492-1	62168	93651-1	Y17-51-S
System Flow	-C3D	1-1/4	0.500"	637219-3C1-B	93645-1	61967-1	93490-1	93491-1	61957-1	93648-1	-----
	-C4D	1-1/4	0.500"	637219-3C4-B	98577-1	66868-1	93490-1	93491-1	61957-1	93648-1	-----

#### DOWNSTREAM VALVE KITS

Valve Kit	(41) "O" Ring	(42) Seat	(43) Ball	(44) Spring
62169	Y328-14	93885	93508-1	93881
62171	Y328-14	93882	98575-1	93881
62237	Y328-14	93558-1	93561-1	93881
62238	Y328-14	93557-1	93560-1	93881
62239	Y328-14	98571-1	98574-1	93881

#### BACK PRESSURE VALVE KITS

Valve Kit	(41) "O" Ring	(42) Seat
61967-1	Y328-19	93522-1
61985-1	Y328-14	93558-1
66868-1	Y328-19	98570-1
66881-1	Y328-14	98571-1

⊕ "Smart parts", keep these items on hand in addition to the service kits for fast repair and reduction of down time.

⊕ Items not shown.

⊕ Except models 651790-XXR-B.

⊕ Includes item 46.

⊕ NOTE: 637219-XXX-B rebuild kits include both 62173 diaphragm service kit and valve kit shown in the chart.

**ASSEMBLY TORQUE REQUIREMENTS**

NOTE: DO NOT OVERTIGHTEN FASTENERS.

- (2) Torque alternately.  
 1.) Snug.  
 2.) 20 - 25 ft lbs. (27.1 - 33.9 Nm).  
 (10) 65 - 75 in. lbs. (7.3 - 8.5 Nm).

**LUBRICATION / SEALANTS**

- ① Apply Perma-Lok® LH150 anaerobic pipe sealant to threads.  
 ② Apply Loctite® nickel anti-seize to threads.  
 ③ Apply 40036 grease to threads.  
 ④ Apply Loctite nickel anti-seize to threads (except on models 65179X-1X-B).

**MATERIAL CODE**

- [A] = Aluminum  
 [Br] = Brass  
 [Bz] = Bronze  
 [C] = Carbon Steel  
 [N] = Neoprene  
 [SS] = Stainless Steel  
 [T] = PTFE

**Upper Regulator Section**

**-XXR Remote Models**  
 (see page 6)

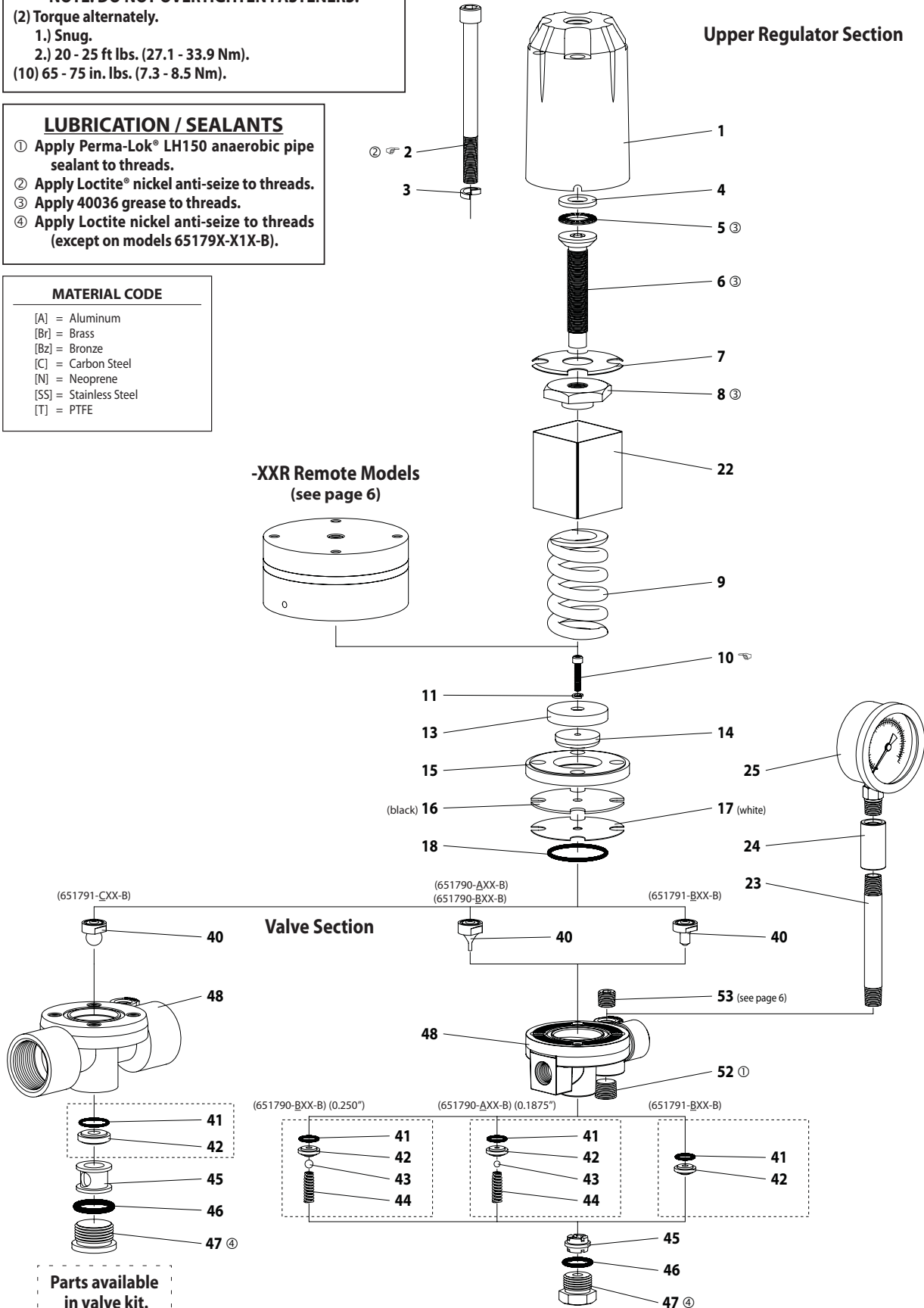

Figure 6



## PARTS LIST

### 651790-XXR-B REMOTE MODELS

Item	Description (size)	(Qty)	Part No.	[Mtl]
30	Air Cap	(1)	93794	[A]
① 31	Diaphragm	(1)	93798	[B]
32	Spacer	(1)	93795	[A]
33	Rivet	(1)	Y193-64	[A]
34	Washer	(1)	90559	[C]
① 35	Piston	(1)	93796	[C]
36	Cap Screw (7/16" - 20 x 1-1/2")	(4)	Y157-74	[C]
37	Adapter	(1)	93752-1	[A]
38	Cap Screw (M8 x 1.25 - 6g x 40 mm)	(4)	93800-2	[C]
53	Pipe Plug (1/4 - 18 NPT) (see page 5)			
	models 651790-X1R-B only	(1)	Y17-51-N	[C]
	models 651790-A3R-B, -A4R-B, -B4R-B and -B5R-B	(1)	Y17-51-S	[SS]

#### ASSEMBLY TORQUE REQUIREMENTS

NOTE: DO NOT OVERTIGHTEN FASTENERS.

(36) Torque alternately.

- 1.) Snug.
- 2.) 20 - 25 ft lbs (27.1 - 33.9 Nm).

(38) Torque alternately.

- 1.) Snug.
- 2.) 10 ft lbs (13.6 Nm).

#### LUBRICATION / SEALANTS

④ Apply Loctite 242® to threads.

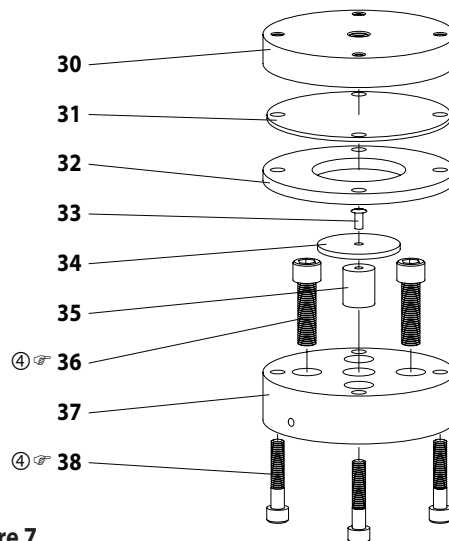

Figure 7

#### MATERIAL CODE

[A] = Aluminum [C] = Carbon Steel  
[B] = Nitrile [SS] = Stainless Steel

① "Smart parts", keep these items on hand in addition to the service kits for fast repair and reduction of down time.

## REGULATOR DISASSEMBLY

(refer to pages 4 and 5)

FOR "WARNINGS", REFER TO "OPERATING AND SAFETY PRECAUTIONS" ON PAGE 2 FOR DETAILS.

BEFORE SERVICING, READ "WARNING: DISASSEMBLY HAZARD." FOUND ON PAGE 2.

**TOOLS REQUIRED:** Small bench vise, 3/8" Allen wrench (Y106-109 is included), 5/32" Allen wrench, a 9/16" Allen wrench for -CXX-B models, torque wrench and Loctite 242.

NOTE: It is not always necessary to remove the regulator from the fluid line to service or inspect only the valve section.

BEFORE DOING ANY IN-LINE SERVICE, ALL FLUID PRESSURE MUST BE RELIEVED. HEED ALL WARNINGS FOUND ON PAGE 2.

**ALLEN WRENCH NOTE:** The Y106-109 (3/8") Allen wrench is included and can be used for several functions including: Regulator adjustment (spring type models), removal and assembly of the long bonnet bolts and the short plate bolts.

**VALVE SEAT NOTE:** Before deciding to order a general repair kit to service the whole regulator, check the easiest things first. Remove and inspect the valve seat for dirt, foreign matter, damage or wear (steps 1 - 3).

#### DOWNSTREAM STYLE MODELS

1. Remove the (46 / 47) base plug / "O" ring assembly, which will allow removal of the (44) spring, (43) ball, (45) flow tube, (42) seat and (41) "O" ring.

#### BACK PRESSURE STYLE MODELS

2. Remove the (46 / 47) base plug / "O" ring assembly, which will allow the removal of the (45) flow tube, (42) seat and (41) "O" ring.
  3. Inspect the (42) seat for dirt, damage or wear.
- READ "WARNING: BONNET REMOVAL HAZARD" FOUND ON PAGE 2.
4. Remove the four (2) long bolts to allow removal of the bonnet / adjusting screw assembly.

NOTE: The (6) adjusting screw, (5) thrust bearing and (4) washer are retained by (7) plate, which is pressed into place. It should not be necessary to disassemble these parts during normal service.

5. Remove the (9) regulator spring and (22) spring stop.
6. Remove the (15) plate.
7. Remove the stem / diaphragm and piston assembly.
8. Place the stem in a vise, locate and secure on the stem flats provided.
9. Using a 5/32" hex Allen wrench, remove the (10) screw.
10. Remove the (11) lockwasher, (13) small plate, two (16, 17) diaphragms and (18) "O" ring from the (40) valve stem.

#### REMOTE MODELS (Refer to figure 7)

1. Remove four (38) screws from (30) air cap and separate the diaphragm assembly from the (37) adapter.
2. Separate the two halves to allow inspection of the (31) diaphragm and replace, if necessary.
3. Remove the four (36) screws, releasing (37) adapter from the base.
4. Reassemble in reverse order.

## REGULATOR REASSEMBLY

Also refer to parts list and views on pages 4 and 5.

1. Place the (10) screw and (11) lockwasher through the (13) plate and into the (14) button.

NOTE: Be certain the radius faces the (16) diaphragm.

2. Locate the (15) plate over the (14) button.
  3. Position the (16) black diaphragm on the (10) screw.
  4. Position the (17) white colored diaphragm in the same manner.
  5. Thread the (40) valve stem onto the small screw and snug hand tight.
  6. Flip the assembly over and place in a vise, locating on the valve stem flats. Use one of the (2) long bolts to align the diaphragms and the plate. The bolt is to help maintain alignment of the diaphragms only at this point (see figure 8).
  7. Hold the plate in this position and tighten the (10) small screw into the stem. NOTE: Torque to 65 - 75 in. lbs (7.3 - 8.5 Nm).
  8. Remove the stem / diaphragm assembly from the vise.
  9. Place the (18) "O" ring into the base groove.
  10. Place the stem / diaphragm assembly on the base and align the bolt holes.
  11. Place the (9) spring and (22) spring stop on the plate.
- NOTE: Spring references do not apply to "-XXR" remote models.
12. Assemble the (1) housing to the (48) base, aligning the four bolt holes.
  13. Retain the housing using four (3) lockwashers and four (2) long bolts. NOTE: Tighten alternately until snug, then torque to 20 - 25 ft lbs (27.1 - 33.9 Nm).
  14. Turn the regulator over and vise on flats.

### DOWNSTREAM MODELS

- Install (41) "O" ring.
- Install (42) seat.
- Install the (45) flow tube.
- Install the (43) ball.
- Install the (44) spring with the narrow end against the ball.
- Install the (47) valve plug and "O" ring assembly.
- Tighten until snug.

### BACK PRESSURE MODELS

- Install (41) "O" ring.
- Install (42) seat.
- Install the (45) flow tube.
- Install the (47) valve plug and "O" ring assembly.
- Tighten until snug.

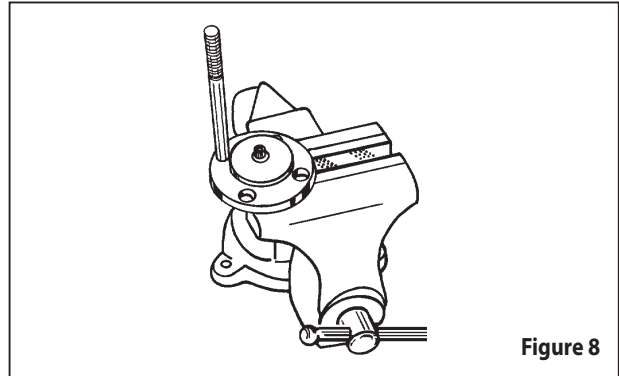

Figure 8

## PERFORMANCE DATA

### Downstream Low Pressure Regulator Models Test Media 55 Centipoise

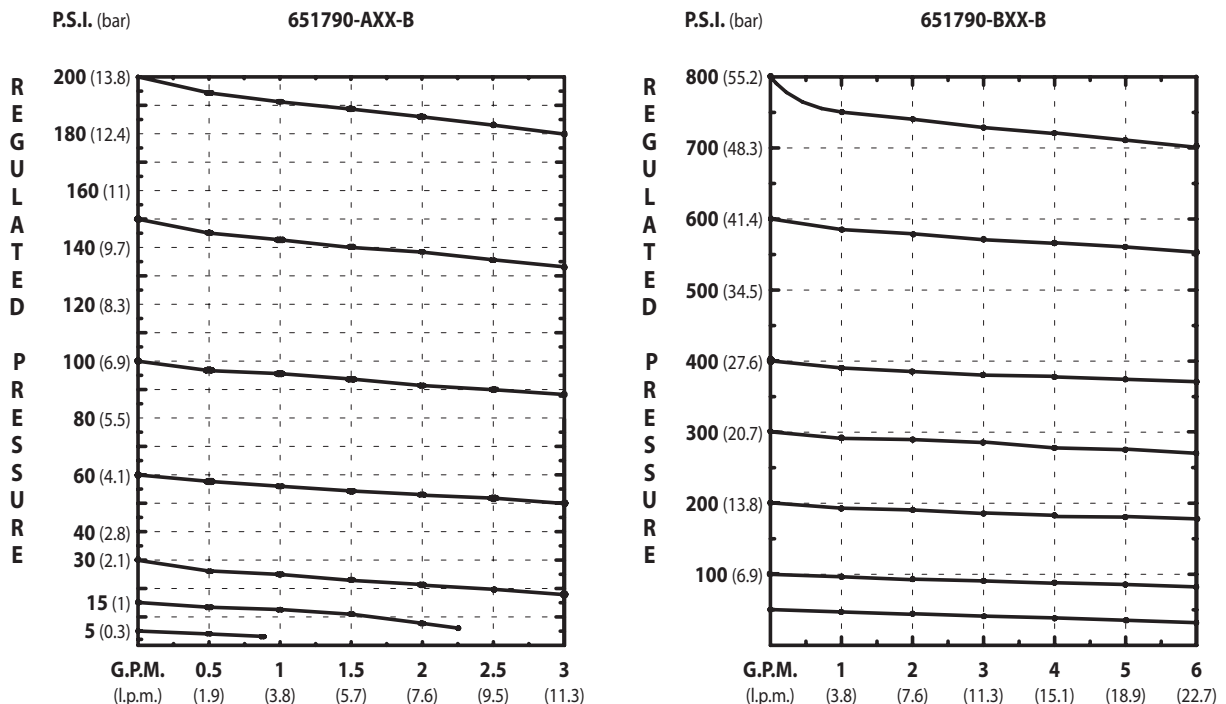
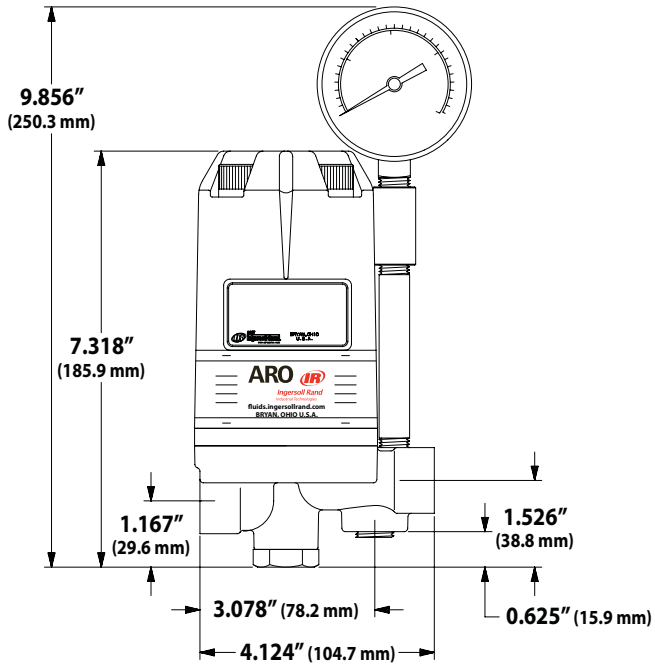

Figure 9

**DIMENSIONAL DATA**

**65179X-AXX-B  
65179X-BXX-B Models**



**651791-CXD-B  
Back Pressure Models**

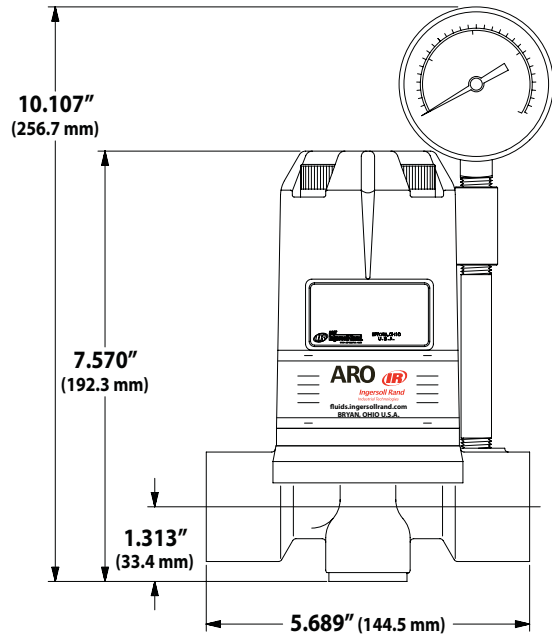

**651790-XXR-B  
Remote Models**

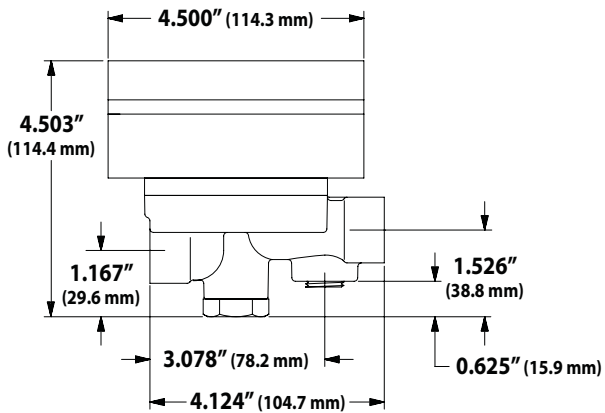

Figure 10